



Yes, you can.®

Invacare® **Birdie™**
Birdie™ Plus
Birdie™ Compact

User Manual



Quality Declaration

Congratulations with your new hoist Invacare® Birdie™ from Invacare® EC-Høng A/S.

Your new hoist is C E -marked in accordance with directive 93/42/EEC concerning medical devices.

Invacare® Birdie™ is developed and constructed with consideration for the user and others handling or assisting with lifting. Furthermore, the hoist is developed in accordance with the European Standard EN 10535.

Invacare® Birdie™ is supervised and quality controlled throughout the entire production process, and the finished hoist is inspected by our finished goods control. Identification label and QA-mark are located on the hoist confirming that the finished goods control has approved the hoist.

Please read the entire user's manual before using the hoist.

Invacare® EC-Høng A/S is certified according to ISO 9001 and ISO 13485.

For and on behalf of Invacare® EC-Høng A/S:



Brian Mundeling
R & D Manager

DE

QUALITÄTSDEKLARATION

Herzlichen Glückwunsch zu Ihrem neuen Patientenlifter Invacare® Birdie™, Birdie Plus™ and Birdie™ Compact von Invacare® EC-Høng A/S.

Ihr neuer Patientenlifter ist gemäß der Richtlinie 93/42/EWG für Medizinprodukte CE-gekennzeichnet.

Der Invacare® Birdie™, Birdie Plus™ and Birdie™ Compact wurde unter Berücksichtigung der Bedürfnisse von Benutzer und Pflegepersonal entwickelt.

Während des gesamten Herstellungsprozesses unterliegt der Invacare® Birdie™, Birdie Plus™ and Birdie™ Compact einer ständigen Qualitätskontrolle und wird im Anschluss nochmals durch unsere Endkontrolle geprüft.

Bitte lesen die gesamte Bedienungsanleitung, bevor Sie den Patientenlifter in Gebrauch nehmen.

Invacare® EC-Høng A/S ist zertifiziert nach ISO 9001 und ISO 13485.

NL

KWALITEITSGARANTIE

Gefeliciteerd met de aanschaf van uw nieuwe plafondlift Birdie™, Birdie Plus™ and Birdie™ Compact van Invacare® EC-Høng A/S.

Invacare® Birdie™, Birdie Plus™ and Birdie™ Compact is CE - gecertificeerd en goedgekeurd conform richtlijn 93/42/EEC betreffende medische hulpmiddelen.

Invacare® Birdie™, Birdie Plus™ and Birdie™ Compact is ontwikkeld en geconstrueerd met inachtneming van de behoeften van de gebruiker en verzorgers.

Gedurende het gehele productieproces is het Birdie™, Birdie Plus™ and Birdie™ Compact bed gecontroleerd op kwaliteitsaspecten en het complete plafondlift is na productie zorgvuldig gecontroleerd.

Wij verzoeken u vriendelijk de gehele gebruikershandleiding te lezen voordat u het plafondlift in gebruik neemt.

Invacare® EC-Høng A/S is ISO 9001 en ISO 13485 gecertificeerd.

IT

DICHIARAZIONE DI QUALITÀ

Complimenti per aver scelto il sollevatore da soffitto Invacare® Birdie™, Birdie Plus™ and Birdie™ Compact prodotto da Invacare® EC-Høng A/S.

Il vostro nuovo il sollevatore da soffitto è marcato CE - ai sensi della Direttiva 93/42/EEC relativa ai dispositivi medici.

Il il sollevatore da soffitto è stato progettato e costruito con un occhio di riguardo per gli utilizzatori e per i loro assistenti. Il sollevatore da soffitto è stato oggetto di accurate verifiche qualitative durante l'intero processo produttivo; una volta completato è stato controllato dal nostro servizio prodotti finiti.

Prima di utilizzare il il sollevatore da soffitto vi invitiamo a leggere integralmente il manuale d'uso.

Invacare® EC-Høng A/S è un'azienda certificata ai sensi della Normativa ISO 9001 e ISO 13485.

ES

DECLARACIÓN DE CALIDAD

Enhorabuena por su nueva elevador de techo Invacare® Birdie™, Birdie Plus™ and Birdie™ Compact de Invacare® EC-Høng A/S.

Su nueva elevador de techo cuenta con el marcaje CE - de acuerdo a la directiva 93/42/EEC que hace referencia a los aparatos médicos.

Invacare® Birdie™, Birdie Plus™ and Birdie™ Compact ha sido diseñada y fabricada teniendo en cuenta a los usuarios y las personas que los asisten.

El proceso de producción del modelo Invacare® Birdie™, Birdie Plus™ and Birdie™ Compact ha sido supervisado en su totalidad y su calidad inspeccionada, por nuestro control de producto acabado.

Por favor lea el manual antes de utilizar la elevador de techo.

Invacare EC-Høng A/S es una empresa certificada ISO 9001 e ISO 13485

FR

DÉCLARATION DE QUALITÉ

Félicitations! Vous avez choisi votre nouveau lève-personnes Invacare® Birdie™, Birdie Plus™ and Birdie™ Compact de Invacare® EC-Høng A/S.

Votre nouveau lève-personnes est marqué CE conformément à la directive 93/42/EEC concernant les dispositifs médicaux.

Invacare® Birdie™, Birdie Plus™ and Birdie™ Compact a été développé et construit en considérant systématiquement les besoins de l'utilisateur et des tierces personnes lors de la manipulation du lève-personnes ou de son utilisation. Invacare® Birdie™, Birdie Plus™ and Birdie™ Compact a été supervisé et contrôlé tout au long du processus de fabrication et le lève-personnes achevé a été inspecté par le contrôle des produits finis. Le lève-personnes répond aux exigences de l'analyse de risques de la norme NF EN 14971. Nous vous remercions de lire le

Manuel de l'utilisateur dans son intégralité avant d'utiliser le lève-personnes.

Invacare® EC-Høng A/S est certifiée ISO 9001 et ISO 13485.

PT

DECLARAÇÃO DE QUALIDADE

Parabéns pela sua nova elevador de transferência Invacare® Birdie™, Birdie Plus™ and Birdie™ Compact da Invacare® EC-Høng A/S.

A elevador de transferência tem a marca CE - em conformidade com a directiva 93/42/EEC referente a aparelhos médicos.

A elevador de transferência foi concebida e desenhada, tendo em consideração o seu utilizador e o seu(s) assistente(s), que o ajudarão a manipular a elevador de transferência.

Durante todo o processo de fabrico e produção, a elevador de transferência Invacare® Birdie™, Birdie Plus™ and Birdie™ Compact foi supervisionada e a sua qualidade controlada, sendo o produto final inspeccionado e testado pelo nosso controlo de qualidade. Por Favor, leia atentamente este manual de utilizador antes de utilizar a sua elevador de transferência.

A Invacare® EC-Høng A/S está certificada em conformidade com ISO 9001 e ISO 13485.

Table of Contents

1. General	6
2. Main parts of the hoist	8
3. Unpacking, assembly and disassembly of the hoist	9
4. Operating the hoist	10
5. Emergency lowering, emergency lifting and emergency stop ..	13
6. Accessories	14
7. Maintenance and cleaning	14
8. Waste disposal	15
9. Trouble-shooting	16
10. Technical specifications	17
11. Symbols	19

Birdie™, Birdie™ Plus and Birdie™ Compact

Thank you for choosing *Invacare®*'s ***Birdie™*** mobile hoist. *Invacare®*'s ***Birdie™*** are especially designed to lift the patient to and from wheelchairs, beds, toilets and floors. ***Birdie™*** hoists offer easy handling and increased comfort within the nursing sector. The design of ***Birdie™*** provides a longer reach, wider leg span and a wider lifting range.

The choice of either electrical or manual leg span combined with the large range of spreader bars and slings available from *Invacare®* makes it easy to adjust the hoist for optimum patient care.

Invacare® EC-Høng is certified according to DS/EN ISO 9001 and ISO 13485 which ensures that our customers are always supplied with products of uniform quality.

Throughout the entire production process, our materials and components are quality controlled by the operators. A final test is made when the product is fully assembled. If the product does not correspond to the quality demands of *Invacare®* EC-Høng, it will not pass quality control.

In the event of a problem in connection with the delivered product, please contact your local *Invacare®* supplier.

Invacare® will take no responsibility if the product is used or assembled in any way other than stated in this user manual. Only accessories mentioned in this user manual may be used on the ***Birdie™*** mobile hoists. This product must only be operated by qualified staff who has received the necessary instruction and training.

Please read this user manual carefully before you are using the mobile hoist.

I. General

- ***Birdie™, Birdie™ Plus and Birdie™ Compact*** are CE-marked in accordance with directive 93/42/EEC concerning medical devices.
- ***Birdie™, Birdie™ Plus and Birdie™ Compact*** have been tested and approved according to EN/ISO 10535.
- Control unit and motors have been approved according to EN 60601.
- ***Birdie™, Birdie™ Plus and Birdie™ Compact*** have undergone a risk analysis according to EN/ISO 14971.
- Control unit, motors and hand control are IPX4 protected.
- Lifting capacity: ***Birdie™*** and ***Birdie™ Plus*** 170 kg, ***Birdie™ Compact*** 150 kg.
- The hoist has an expected lifetime of 8 years.
- The hoist will not operate when in charge mode.

Disconnect the charger from the hoist before moving or using the hoist. Make sure the mains cable is not squeezed or damaged when assembly or disassembly of the hoist or when moving the hoist.

If the functions of the hoist change, please see the section "Maintenance and cleaning". This product must be serviced and maintained by qualified personnel.

Please be aware of the following possible risks when using the hoists:



The hoist must be carefully supervised if the patient is a child.



Please note that it is more difficult to manoeuvre the hoist on carpeted or uneven/textured surfaces as opposed to wooden or flat surfaces; this is due to the starting forces required to initiate the movement that may create additional friction exerted on the castors.



It is recommended not to move the user with the jib at maximum height. Take great care when moving the hoist on carpeted, wet, slippery, rough or uneven surfaces. Never use on slopes.



Caution! Never attempt to lift a patient outside the base area of the hoist. When lifting a patient from the floor, the patient must always be located between the two hoist legs, and never outside this area. To avoid injury, utmost care must be taken when raising and lowering a patient.



Invacare[®] accepts no liability for any use, change or assembly of the **Birdie**[™], **Birdie**[™] **Plus** and **Birdie**[™] **Compact** hoists other than as stated in this user manual.



There is a risk of squeezing and entrapment during operation and transport of the hoist.



Never exceed the maximum recommended lifting capacity.



It is important that the cables do not become entrapped or jammed in moving parts and castors during operation and transport.



Important! *Invacare*[®] recommend that operation of any mobile lifting equipment is carried out by personnel with prior professional training in moving and handling techniques.



Always choose the sling design and size according to the patient's weight, size and physical ability. Always ensure, that the sling is applied correctly. Never leave a patient in the sling unattended.



Please ensure that the hoist is not exposed to water, as this can cause damage.



Locking pin must be located into the base position when transporting the hoist. Failure to do so may cause injury during handling.

2. Main parts of the hoist

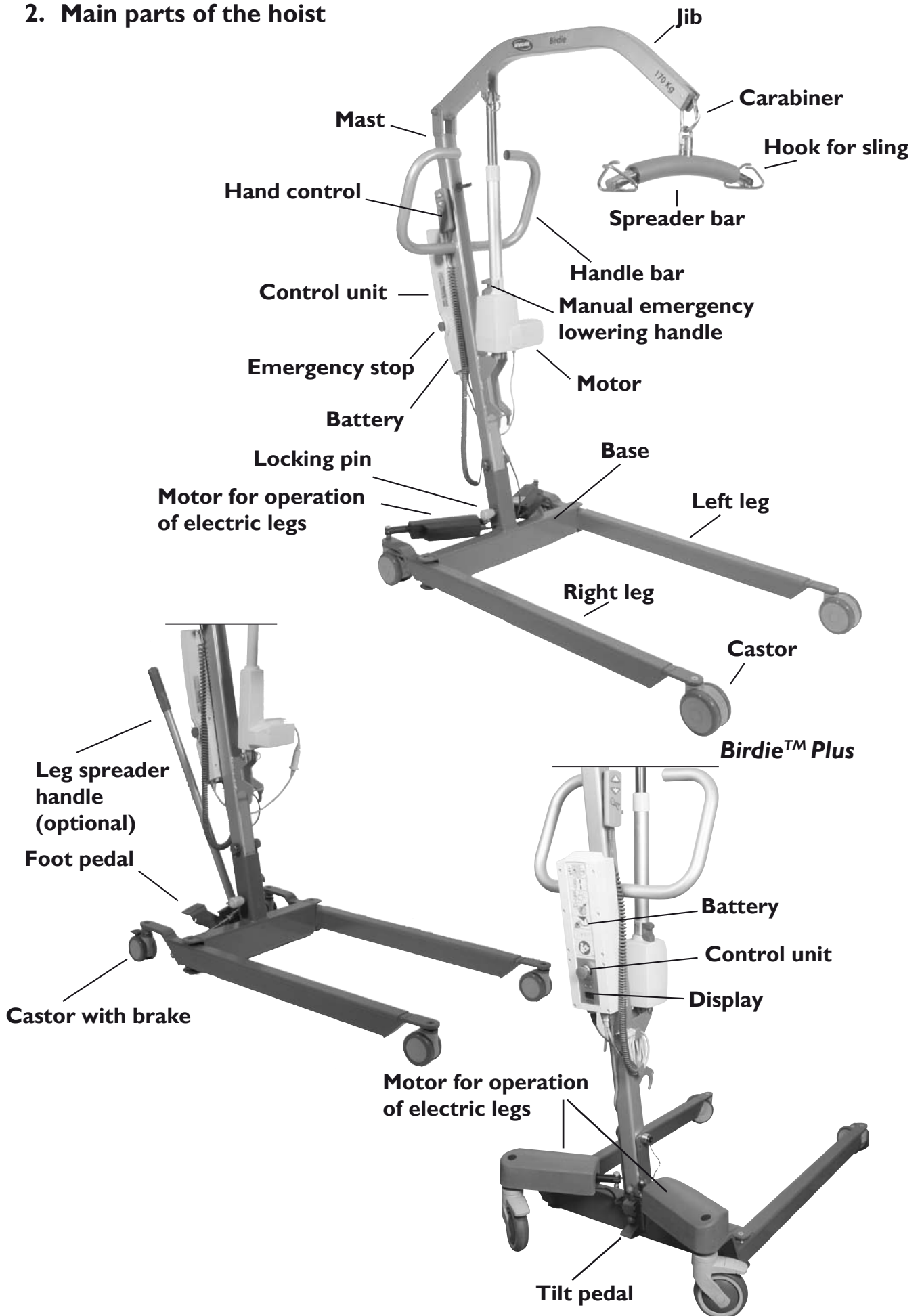

3. Unpacking, assembly and disassembly of the hoist

- The packaging is developed for optimal protection of the hoist.
- If you return the hoist, it must be packed as delivered in the original box.
- You can order replacement boxes from *Invacare®*.

Unpacking

1. Should the packaging be damaged upon receipt, each part of the packaging must be examined for visible defects. In the event of any damage, please contact *Invacare®*.
2. Carefully take out and identify all the parts in the box.
3. The box contains the following parts:
 - 1 hoist
 - 1 mains cable
 - 1 user's manual
 - 1 spreader bar
 - 1 manual leg spreader handle (optional)
 - 1 sling (optional)

To prevent self-discharging of the battery or accidental operation of the hoist, the emergency stop is activated during shipping. Please remember to deactivate the emergency stop and charge the battery prior to first use.

Assembling of the hoist

The hoists are easy to assemble without the use of tools.

1. Perform unpacking and assembly operation at floor level
2. Take out all the parts of the box (picture 1-4).
3. Apply castor brakes before assembling hoist.
4. Remove the locking pin and raise the mast of the hoist by pulling the handle bar (picture 5-6).
5. Insert the locking pin (picture 7 and 12-13 below). Ensure that the locking pin is correctly inserted as the picture 12.
6. Loosen the spreader bar by pulling it downwards (picture 8).
7. Remove the pipe pin. Assemble the motor and the jib by using the pipe pin (picture 9-10).
8. Correctly assembled hoist (picture 11).

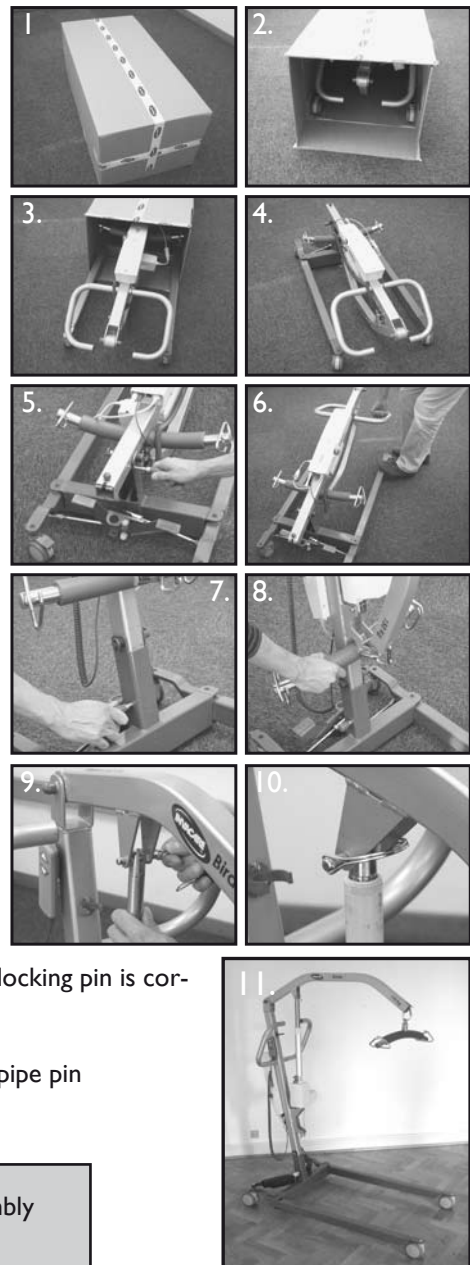



Activate the emergency stop before assembly or disassembly to prevent entrapment/squeezing.
Remove optional leg spreader handle before disassembly.



There is a possible risk of squeezing of both limbs and wires during assembly and disassembly of the hoist. Take the utmost care when lifting components during assembly - some parts are heavy. Always remember to adopt the correct lifting position.



Ensure that the locking pin is correctly inserted.

Locking pin **correctly** inserted.



Locking pin **incorrectly** inserted.



Disassembling of the hoist

1. Lower the jib and narrow both legs completely, and activate the emergency stop button.
2. Apply castor brakes before disassembling hoist.
3. Remove the pipe pin and the motor piston from the jib, reinstall the pipe pin in the piston end, and lock the motor into the clips on the mast.
4. Attach the spreader bar into the welded fork on the mast.
5. Remove the locking pin from the base of the mast, release the safety latch, lower the mast, and relocate the locking pin into the mast near the suspension axle of the mast.

The hoist can now be located in the packaging box, pulled on the rear wheels, or parked in an upright position with the mast/jib assembly pointing upwards

4. Operating the hoist

Lifting capacity

Birdie™ and **Birdie™ Plus**: 170 kg.

Birdie™ Compact: 150 kg.



Operation of the manual leg spread

The manual leg span is operated by the 2 pedals on the leg section of the hoist. The pedals are operated from one side to the other to adjust the distance between the legs of the hoist.

The hand control has 2 buttons – one to raise and one to lower the jib.

1. Stand behind the hoist and take a firm hold of the handle bar using both hands.
2. Using your foot, press the left pedal on the base to increase the distance between the legs.
3. Using your foot, press the right pedal to decrease the distance between the legs.

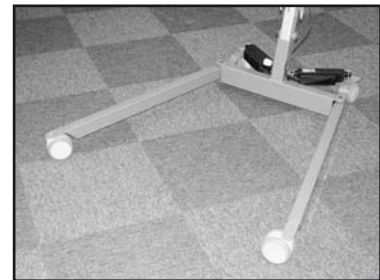

Operation of the electric legs

The distance between the legs is controlled by 2 electric motors controlled by the hand control.

The hand control has 4 buttons: 2 for raising and lowering the jib and 2 for operating the electric legs.

Using the hand control

1. Press “arrow up” on the hand control to raise the jib.
2. Press “arrow down” on the hand control to lower the jib.
3. Operation of the electric legs.

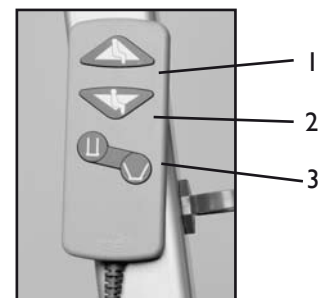

Operating forces of buttons: Max. 5 N.

LED diodes on the control unit

Birdie™ and **Birdie™ Compact** - the upper yellow diode will blink during charging, and switch to continuous light when fully charged. The lower green diode will light continuously when the control unit is connected to the mains, and light up when any button on the remote control is pressed, or when the electric emergency lowering is activated.

Birdie™ Plus - the left green diode will light continuously when the control unit is connected to the mains. The yellow right diode will light continuously during charging, and go out when the battery is fully charged. There is no indication when hand control buttons are pressed, or when the emergency lowering/raising system is activated.



Brakes

1. Stand behind the hoist and take a good hold of the handle bar.
2. Press the pedals downwards by feet on the back castors to activate the brake.
3. Press the pedals upwards by feet to release the brake.

Moving the hoist

1. Stand behind the hoist and take a good hold of the handle bar.
2. Release the brakes of the back castors.
3. Now the hoist can be pushed or pulled to the desired location.

Note: To negotiate raised obstacles during movement of the unloaded hoist, it is recommended to pull the hoist backwards. This operation should only be performed when the hoist is in the unloaded condition.

Tilt pedal

The tilt pedal is used for tilting when the hoist must be moved from one room to another, to force a footstep. Place one foot on the tilt pedal, and pull the empty hoist rearwards to a suitable angle.



WARNING! Never use the tilt pedal with a patient in the hoist.

Mounting the spreader bar

The spreader bar is easy mounted and dismantled on the carabineer hook:

Open the carabineer hook with one finger, and mount or dismount the spreader bar.

Use only spreader bars made for the **Birdie™** mobile hoists.

Make sure the spreader bar is suitable for the patient and the actual lift or transfer required.



Carabineer correctly positioned on the lifting arm, ready for use.

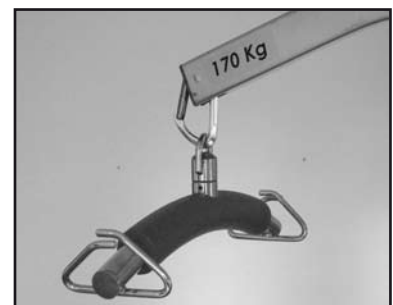

Correctly attached spreader bar.



Easy opening of the carabineer by pushing the safety catch backwards with one finger and attachment of the spreader bar.

Fitting the sling

Slings designed for 2- or 4-point spreader bars can be used with this mobile hoist, please refer to *Invacare*®'s sling brochure for details.

Note: The size of the sling and the width of the spreader bar should correspond.

1. Choose the most appropriate sling for the patient. The carer must be trained in the use of hoists before performing any transfers.
2. Carefully inspect the hoist and the sling. If defective parts are found, the damaged parts must be replaced.
3. Only use slings suited for the hoist and the patient.
4. Place the patient in the sling as described in the sling manual. Pay special attention to the fact that the sling is correctly applied.
5. Lower the jib and mount the straps of the sling. If the patient is in a sitting position, the jib must be lowered to chest height and the hoist must be moved as close as possible to the patient.
6. Make sure that there are no obstructions when raising the jib. Ensure that brakes are not engaged before lifting or lowering.



Caution! Do not lift or lower a patient with the brakes applied. Always let the hoist find the correct centre of gravity. Make sure that the lifting area is between the legs of the hoist. **Never** operate the hoist when the patient is outside the base and leg area. Always be careful when lifting or lowering a patient. Never exceed the maximum recommended lifting capacity.

Charging the battery

The hoists are equipped with an internal charger. It is recommended to charge the batteries regularly to ensure optimal use of the hoist and prolong the life of the batteries. Furthermore, it is recommended to charge the batteries before first use.

The control unit is equipped with a sound signal, which will beep when operating with low battery capacity. It is recommended to charge the batteries as soon as the sound signal is heard. In addition, *Birdie™ Plus* is equipped with a display, indicating the approximately remaining battery capacity.

How to charge the batteries:

1. Connect the mains cable to the control unit and plug it in. It takes about 4 hours to charge the batteries. Charging must take place in a room with good air ventilation. The charger stops automatically when the batteries are fully charged.
2. Remember to disconnect the charger cable before using the hoist again.



The emergency stop must not be activated - otherwise it will be impossible to charge the batteries. While charging takes place the hoist cannot be used. Do not use or move the hoist without unplugging from the socket outlet. Do not attempt to use the hoist if the battery housing is damaged. Replace a damaged battery housing before further use.

5. Emergency lowering, emergency lifting and emergency stop

Electric emergency lowering *Birdie™*, *Birdie™ Compact* and *Birdie™ Plus*

If the hand control fails, the jib can be lowered by using the circular switch for emergency lowering. This is located at the front of the control unit. The jib will be lowered as long as the button is pressed. On *Birdie™ Plus* the button should be operated by means of a sharp object, such as a pencil.

Birdie™ and *Birdie™ Compact*



Emergency lowering

Birdie™ Plus

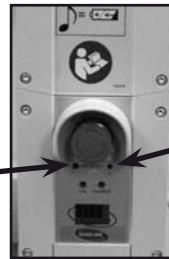

Emergency lowering

Emergency lifting

Electric emergency lifting - *Birdie™ Plus*

If the hand control fails, the jib can be raised by using the button for emergency lifting. This is located at the front of the control unit, and should be operated with a sharp object, such as a pencil. The jib will be lifted as long as the button is pressed.



Manual emergency lowering - *Birdie™* and *Birdie™ Plus*

In case of partial or total power failure, or if the battery runs down while using the hoist, *Birdie™* and *Birdie™ Plus* is equipped with a manual emergency lowering system located at the bottom of the motor. The weight is preset for 75 kg. If the patient's weight is more or less than 75 kg, it might be necessary to adjust the manual emergency lowering.



Adjustment of the manual emergency lowering - *Birdie™* and *Birdie™ Plus*

If the lowering speed has to be adjusted according to the patient's weight, then the screw in the red release handle must be adjusted. Loosen to increase the speed and tighten to decrease the speed.

Note: Manual emergency lowering is only possible when a patient is sitting in the hoist.

Emergency stop

In case of emergency: Press the red button for emergency stop. The emergency stop can be reset by turning the stop button

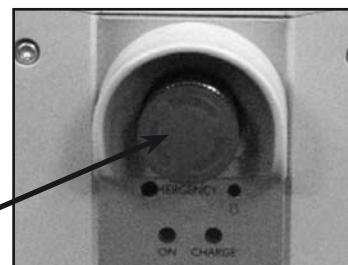

Note!

The mechanical emergency lowering system will only operate when there is a patient in the hoist. The mechanical emergency lowering system has to be adjusted according to the patient's weight.

6. Accessories

	Ordering numbers
Spreader bar, 350 mm, 2 points	1446274-0152
Spreader bar, 450 mm, 2 points	1507415-7012
Spreader bar, 550 mm, 2 points	1507417-7012
Spreader bar, 450 mm, 4 points	1507418-7012
Spreader bar, 550 mm, 4 points	1513442-7012
Castor, Ø75 mm, with brake, 1 pcs.	1510645-7012
Castor, Ø100 mm, with brake, 1 pcs.	1510803-0125
Castor, Ø75 mm, (electric Birdie™) with brake, 1 pcs.	1510802-7012
Castor, Ø100 mm, (electric Birdie™) with brake, 1 pcs.	1510804-0125
Castor, Ø125 mm, (Birdie™ Plus) with brake, 1 pcs.	1522073-0125
Castor, Ø75 mm, 1 pcs.	1510642-0125
Castor, Ø100 mm, 1 pcs.	1510643-0125
Handle for manual leg spread	1510505-9006
Packaging box (Birdie™)	1511776
Packaging box (Birdie™ Plus)	1514780
Packaging box (Birdie™ Compact)	1511779
Packaging insert (Birdie™ and Birdie™ Plus)	1511777
Packaging insert (Birdie™ Compact)	1511778
Polystyrene support (Birdie™ and Birdie™ Compact)	1513628
Polystyrene support (Birdie™ Plus)	1514781
Scale with display (for carabiner attachment)	1513627
Sling	See the sling brochure

7. Maintenance and cleaning

At normal daily operation, a service check-up should take place every year, according to the maintenance chart. When performing annual or regular maintenance, all parts designed to carry load must be as a minimum tested with maximum load. All safety features must be checked according to EN ISO 10535: 2006 Annex B.

The hoist must be stored at normal room temperature. If it is stored in a damp, cold or wet environment then the motor and other mounting parts may be prone to corrosion.

- The hoist have been designed so that it requires a minimum amount of maintenance.
- It is recommended that the batteries are charged frequently, if possible every night, as it will extend the lifetime of the batteries and will ensure high performance.
- It is recommended that the hoist is cleaned after use.
- Please check that the spreader bar connections, control unit and motors are in good working order and not damaged in any way. If there is any damage to the hoist, refrain from using it, and contact your local *Invacare®* dealer before further use.

Wear and damage of loading parts

It is necessary to maintain and check all parts that are exposed to static or dynamic strain, such as the sling, the spreader bar and the turning points, do not have fractures, are fragile, askew or damaged. Damaged parts must be replaced before further use.

Cleaning

- To prevent cross-infection, the hoists must be cleaned after use.
- The hoist must be wiped with a moist firmly wrung cloth with ordinary household disinfectants.
- Only use officially approved disinfection detergents.
- Dry the hoist carefully after cleaning.
- Never use acids, alkaline or solvents for cleaning the hoist.

Motors, control unit and mounting parts can be destroyed if the hoist is cleaned in any other way than stated above.

Maintenance chart

Only personnel having received the necessary instruction or training by Invacare® must perform service and maintenance on Birdie™, Birdie™ Plus and Birdie™ Compact.					
Serial number (located on the hoist base): _____					
Date:	Initials:				
Visual inspection of all hoist parts					
Inspection of the spreader bar and carabiner - welding and assemblies					
Inspection of the motors - undamaged					
Inspection of cables and plugs - undamaged					
Inspection of emergency stop, electrical emergency lowering and -raising (only Birdie™ Plus)					
Inspection of the castors - attachment, braking ability and free rolling					

Invacare® offers courses in service and maintenance of the hoist.

For all servicing and maintenance requirements, please contact your local Invacare® dealer.

8. Waste disposal

This product has been supplied from an environmentally aware manufacturer that complies with the Waste Electrical and Electronic Equipment (WEEE) Directive 2002/96/CE.

This product may contain substances that could be harmful to the environment if disposed of in places (landfills) that are not appropriate according to legislation.

The 'crossed out wheelee bin' symbol is placed on this product to encourage you to recycle wherever possible.

Please be environmentally responsible and recycle this product through your recycling facility at the end of it's life.

9. Trouble-shooting

Only personnel having received the necessary instruction or training by *Invacare*[®] must perform service and maintenance on *Birdie*[™], *Birdie*[™] *Plus* and *Birdie*[™] *Compact*.









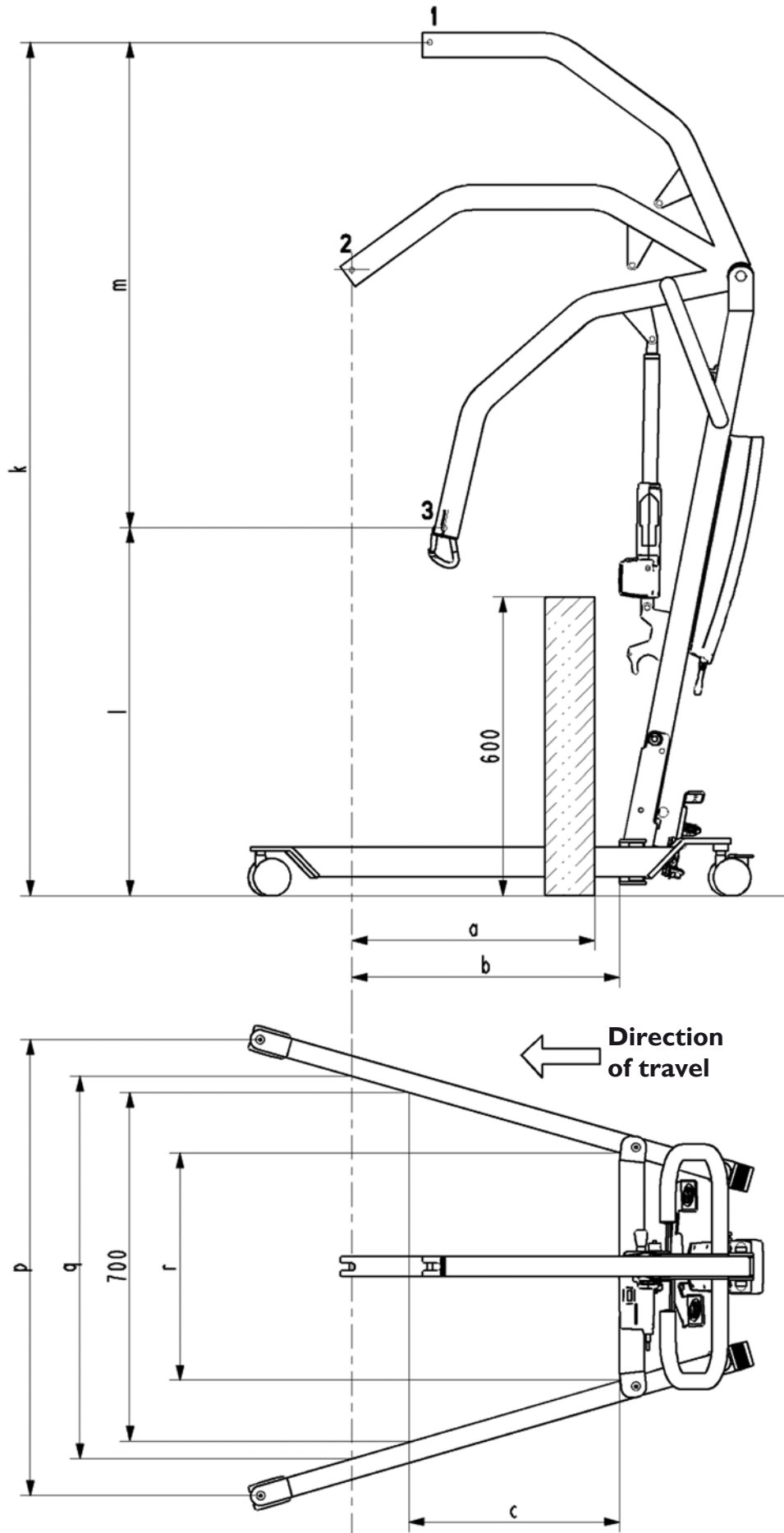

Symptom	Possible cause	Remedy
The mast seems loose	The mast axis screw has become loose	Insert the locking pin into the mast axis screw, and tighten the screw
Castors are noisy	Dust or dirt in the castors	Clean the castors
Hinge between jib and mast is noisy during operation	Missing lubrication	Lubricate the hinge
The motor is not running	Hand control or motor is not connected	Insert the plugs fully
	No power on the battery	Charge or replace the battery
	The red emergency stop is activated	Turn the red button clockwise to deactivate
Motor noise, but no movement in the piston rod	Motor is damaged	Replace the motor
The piston rod only moves in and not out	Motor is damaged	Replace the motor
The control unit emits a beeping sound during lifting, and the jib motor stops (<i>Birdie</i> [™] and <i>Birdie</i> [™] <i>Compact</i>). The jib motor stops (<i>Birdie</i> [™] <i>Plus</i>)	Max. load is exceeded	Reduce the load (and the hoist will function normally)

Contact your dealer if the above does not solve your problems.

Lubricate with medically clean oil, e.g. Kemitura Kem Lub KEM-WO 50, order no. 813239.

10. Technical specifications



General specifications		Manual and electric Birdie™		Birdie™ Plus	Manual Birdie™ Compact	
	Castor	Ø 75 mm	Ø 100 mm	Ø 100 mm + Ø 125 mm	Ø 75 mm	Ø 100 mm
	Maximum lifting capacity	170 kg		170 kg	150 kg	
	Lowest position (min. height of CSP**) 3* I*	65,5 cm	67 cm	67 cm	73 cm	74,5 cm
	Lifting area (height range)	46,5 - 168,5 cm	47,5 - 170 cm	47,5 - 170 cm	51,5 - 158,5 cm	53 - 160 cm
	Maximum height of CSP** k*	189 cm	190,5 cm	190,5 cm	180 cm	181,5 cm
	Leg length	115 cm		116,5 cm	100 cm	
	Minimum internal width r*	58 cm		58 cm	46 cm	
	Total width (closed), external measure	65,5 cm	68 cm	68 cm	53 cm	55 cm
	Internal width at maximum reach q*	91 cm		91 cm	78 cm	
	Total width (open) internal measure	104 cm		104 cm	89 cm	
	Total width (open) centre to centre of castor p*	108,5 cm		108,5 cm	93 cm	
	Turning radius	140 cm		140 cm	107 cm	
	Weight, mast, incl. battery, excl. spreader bar	21 kg		21,5 kg	17,5 kg	
	Total weight incl. spreader bar	42 kg		44 kg	36 kg	
	Weight, leg section *	19 kg		21 kg	16,5 kg	
	Height to upper edge of legs	10 cm	11,5 cm	11,5 cm	10 cm	11,5 cm
	Min. free height	2 cm	3,5 cm	3,5 cm	2 cm	3,5 cm
	Min. space for patient (to (motor) in top position a*	34 cm		34 cm	30 cm	
	Maximum reach at 60 cm b*	66,5 cm		66,5 cm	54,5 cm	
	Maximum reach from base c*	66,5 cm		66,5 cm	54,5 cm	
	Reach from base with legs spread to 70 cm m*	24 cm		24 cm	41,5 cm	
	Hoisting range	123,5 cm		123,5 cm	107 cm	
	Voltage output	24 V $\overline{=}$ max. 250 VA				
	Voltage supply	100 -240 V $\overline{=}$ 50/60 Hz				
	Max. current input	Max. 200 mA		Max. 400 mA	Max. 200 mA	
	Operating temperature.	5° to 40° C				
	Air humidity	20% to 90% @ 30° C - not condensing				
	Sound pressure	45-50 dB(A)				
	Atmospheric pressure	700 to 1060 hPa				
	Protection class, control unit	IPX4				
	Protection class, hand control	IPX4				
	Protection class, motor	IPX4				
	Insulation class	II - type B				
	Working ability	40 full lifts without battery charge with batteries at 50% of full capacity				
	Intermittens	10%, max. 2 minutes/18 minutes				
	Battery capacity	2,9 Ah		2,9 Ah + display	2,9 Ah	
	Manual emergency lowering	Yes		Yes	No	
	Electric emergency lowering/lifting	Yes/No		Yes/Yes	Yes/No	

All measurements are given including a 45 cm 2 point spreader bar, except dimensions marked with *.
Invacare® reserves the right to change the measurements without warning.

** CSP: Central Suspension Point

1: Highest position, 2: Maximum reach position, 3: Lowest position

11. Symbols

The patient is not separated from the ground and the chassis:



Direct current:



Alternating current



Double insulated:



X kg max. load (SWL) = (Patient + sling + spreader bar).

X = 150 kg (***Birdie™ Compact***)

X = 170 kg (***Birdie™ and Birdie Plus™***)



The product should be reused where possible:



Refer to user's manual:





Yes, you can.®

Customer Sales and Service

Denmark

INVACARE A/S

Sdr. Ringvej 37
DK-2605 Brøndby
Phone: +45 36 90 00 00
Fax: +45 36 90 00 01
www.invacare.dk
denmark@invacare.com

Sweden & Finland

INVACARE AB

Fagerstagatan 9 / Box 66
S-163 91 Spånga
Phone: +46 8 761 70 90
Fax: +46 8 761 81 08
www.invacare.se
sweden@invacare.com

Norway & Iceland

INVACARE AS

Grensesvingen 9
Postbox 6230 Etterstad
N-0603 Oslo
Phone: +47 22 57 95 00
Fax: +47 22 57 95 01
www.invacare.no
norway@invacare.com

Spain

INVACARE S.A.

C/Areny S/N
Poligon Industrial de Celrà
E-17460 Celrà (Girona)
Phone: +34 972 49 32 00
Fax: +34 972 49 32 20
www.invacare.es
contactsp@invacare.com

Switzerland

MOBITEC REHAB AG

Benkenstrasse 260
CH-4108 Witterswil
Phone: +41 61 487 70 80
Fax: +41 61 487 70 81
switzerland@invacare.com

Invacare® EC-Høng A/S

Ident. no.: 1515013

Version: 03

Date: 05.2009

Belgium & Luxemburg

INVACARE N.V.

Autobaan 22
B-8210 Loppem, Brügge
Phone: +32 50 83 10 10
Fax: +32 50 83 10 11
www.invacare.be
belgium@invacare.com

Netherlands

INVACARE B.V.

Celsiusstraat 46
NL-6716 BZ Ede
Phone: +31 318 695 757
Fax: +31 318 695 758
www.invacare.com
nederland@invacare.com
csede@invacare.com

Germany

INVACARE AQUATEC GmbH

Alemannenstrasse 10
D-88316 Isny
Phone: +49 75 62 7 00 0
Fax: +49 75 62 7 00 66
www.invacare-aquatec.com
info@invacare-aquatec.com

Portugal

INVACARE Lda

Rua Estrada Velha 949
P-4465-784 Leça do Balio
Phone: +351 225 1059 46/47
Fax: +351 225 1057 39
www.invacare.pt
portugal@invacare.com

Australia

INVACARE Australia Pty Ltd

1 Lenton Place, North Rocks
NSW 2151
Phone: +61 2 8839 5333
Fax: +61 2 8839 5353
www.invacare.com.au
sales@invacare.com.au

3rd party certified
according to
EN ISO 9001
EN ISO 13485

France

INVACARE Poirier S.A.S

Route de St. Roch
F-37230 Fondettes
Phone: +33 2 47 62 64 66
Fax: +33 2 47 42 12 24
www.invacare.fr
contactfr@invacare.com

Italy

INVACARE MECC SAN S.R.L.

Via dei Pini 62
I-36016 Thiene (VI)
Phone: +39 0445 38 00 59
Fax: +39 0445 38 00 34
www.invacare.it
italia@invacare.com

United Kingdom & Ireland

INVACARE LTD

South Road
Bridgend Industrial Estate
UK-Bridgend, CF31 3PY
Phone: +44 1 656 664 321
Fax: +44 1 656 667 532
www.invacare.co.uk
uk@invacare.com
ireland@invacare.com

New Zealand

INVACARE NZ

4 Westfield Place,
Mt. Wellington
Auckland
Phone: +64 9 917 3939
Fax: +64 9 917 3957
www.invacare.co.nz
sales@invacare.co.nz

Austria

MOBITEC MOBILITÄTSHILFEN GmbH

Herzog Odilostrasse 101
A-5310 Mondsee
Phone: +43 6232 5535 0
Fax: +43 6232 5535 4
www.mobitec-austria.com
austria@invacare.com

Manufacturer:

INVACARE EC-Høng A/S

Østergade 3
DK-4270 Høng
www.invacarebeds.dk